

# The Anatomy of: The Saino Models 3000 & 4000 Sliding Fire Door



**Designed where High Usage and Up To A 4-Hour Label are Required**

Both models are custom manufactured and available in single slide or center parting with UL and FM label ratings of 20 minutes to 4 hours. Standard features include automatic close system with thermal heat detectors and low maintenance heavy-duty hardware.

Optional Track Hood is available in 18 gauge cold rolled prime painted steel or stainless steel.

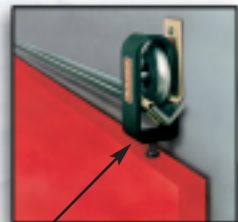

The patented Easy Roll track system gives Models 3000 & 4000 the lowest friction of any fire door on the market.

Both models are equipped with a weight or reel type closing system (control speed closing optional) 2" x 2" x 3/8" angle track system, 5-1/4" diameter wheels and thru wall linkage. All hardware is UL labeled and prime painted.

Optional vision panel, panic hardware and pass door.

The door is shipped prime painted with a high quality gray rust resistant paint. Optional finishes include galvanized, stainless steel or powder coated.

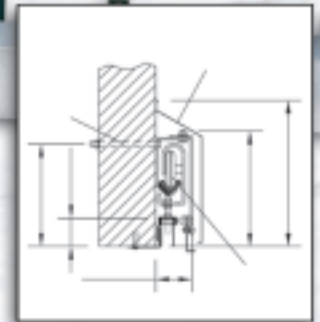
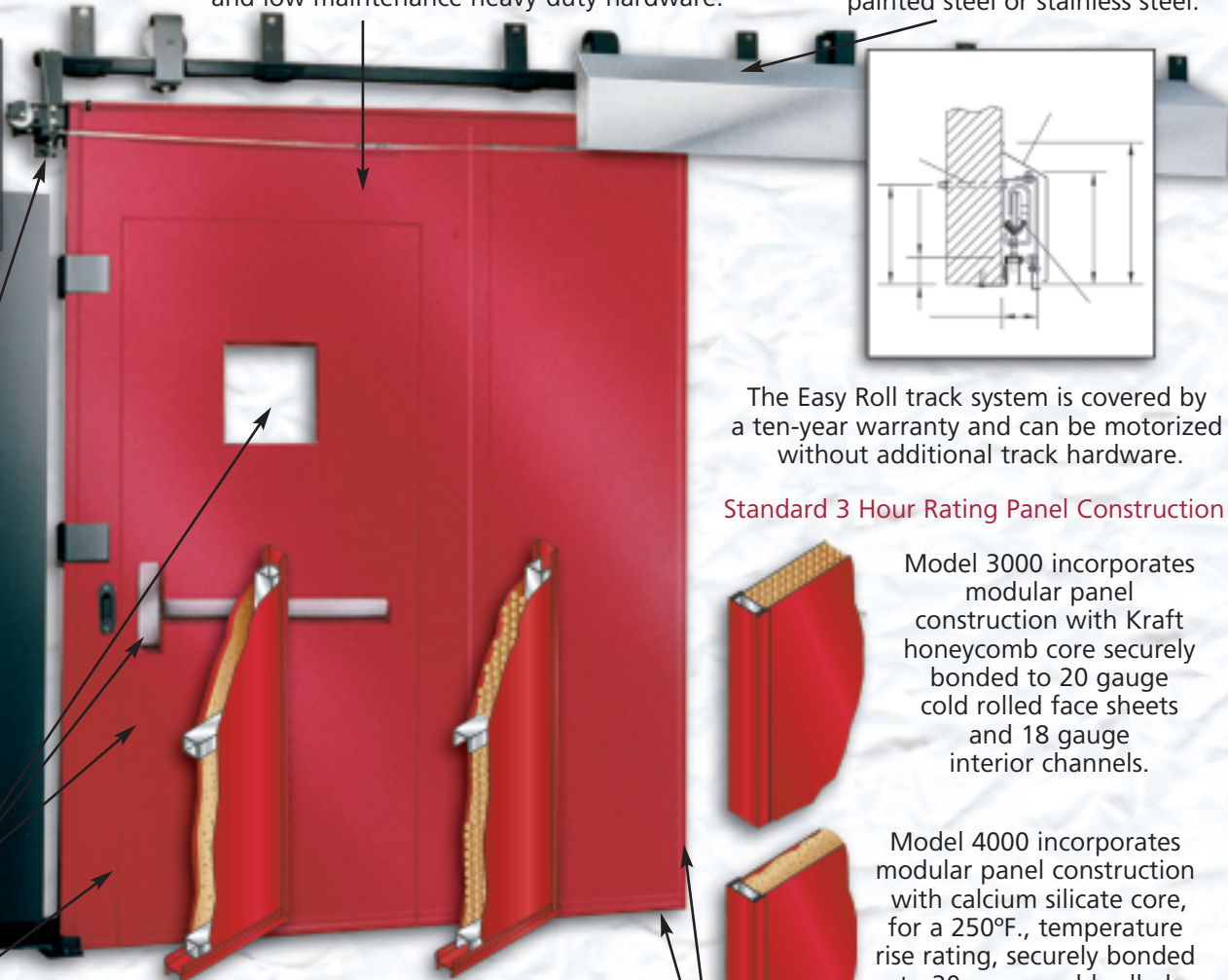

The Easy Roll track system is covered by a ten-year warranty and can be motorized without additional track hardware.

## Standard 3 Hour Rating Panel Construction

Model 3000 incorporates modular panel construction with Kraft honeycomb core securely bonded to 20 gauge cold rolled face sheets and 18 gauge interior channels.

Model 4000 incorporates modular panel construction with calcium silicate core, for a 250°F., temperature rise rating, securely bonded to 20 gauge cold rolled face sheets and 18 gauge interior channels.

## Optional 4 Hour Rating Panel Construction

Model 4000/4 incorporates steel tubing construction and a calcium silicate core. Model 3000 has a Kraft honeycomb core.

Model 3000/4 incorporates 12 gauge channel and Kraft honeycomb core. Model 4000 has calcium silicate core.

The panels are assembled with 14 gauge capping channel and a 10 gauge bottom guide roller channel.

Visit our website for downloadable drawings and specs.

## Applications

- Food Processing
- Industrial
- Institutional
- Pharmaceutical
- Warehouse
- Commercial Applications

## Environment

- Personnel
- Interior
- Exterior
- Loading Dock

## Traffic

- Forklifts
- Motorized Pallets
- Pedestrian

## Options

- 1900 Operator with Battery Backup & Heat Detectors
- Perimeter Gasketing
- Locking Devices
- Spark Proof Hardware
- Crush Plates
- Monorail Cutouts

 **Chase Doors**  
World's Leading Manufacturer of Traffic Doors

800-543-4455 • Fax 800-245-7045 • [www.chasedoors.com](http://www.chasedoors.com) • [email-info@chaseind.com](mailto:email-info@chaseind.com)

